

Low boarding

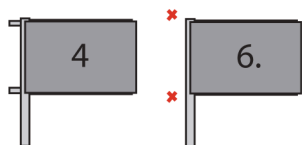

037-101	1 PCS	037-120	1 PCS	100-211	6 PCS
HPL plate		Low vertical member		Bolt M8 x 30 mm secured	
037-351	1 PCS	037-341	1 PCS	100-405	PCS
Girder top		Girder bottom		NPDM 10 x 2 mm	

100-401	PCS
NPDM 25 x 5 mm	

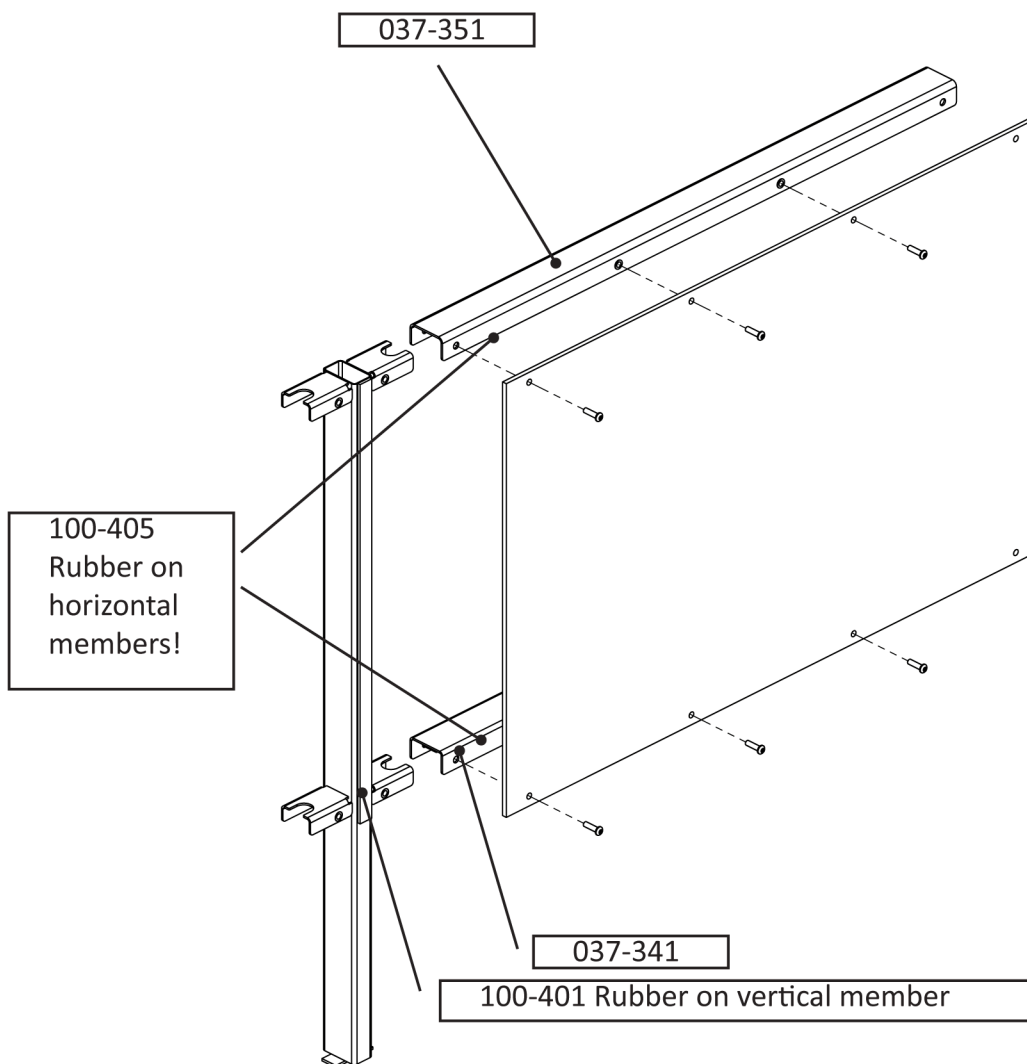

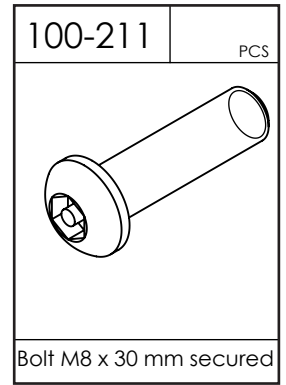
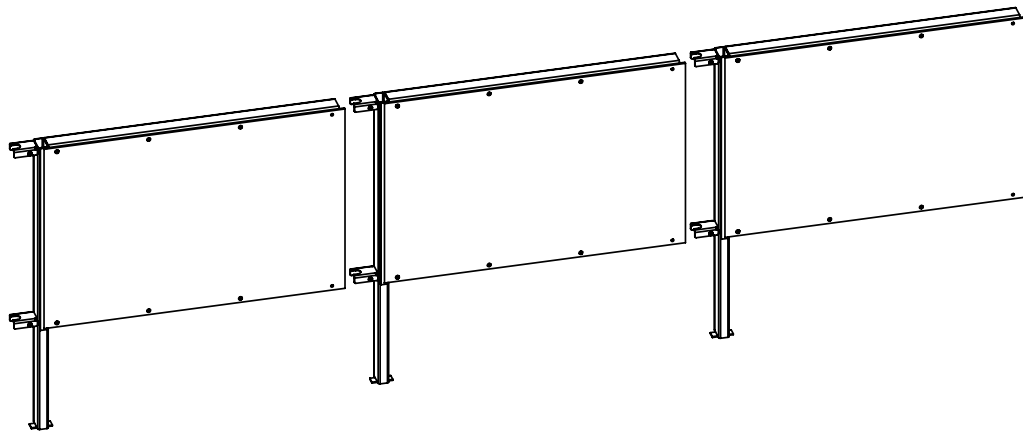

25 mm between boarding and ground

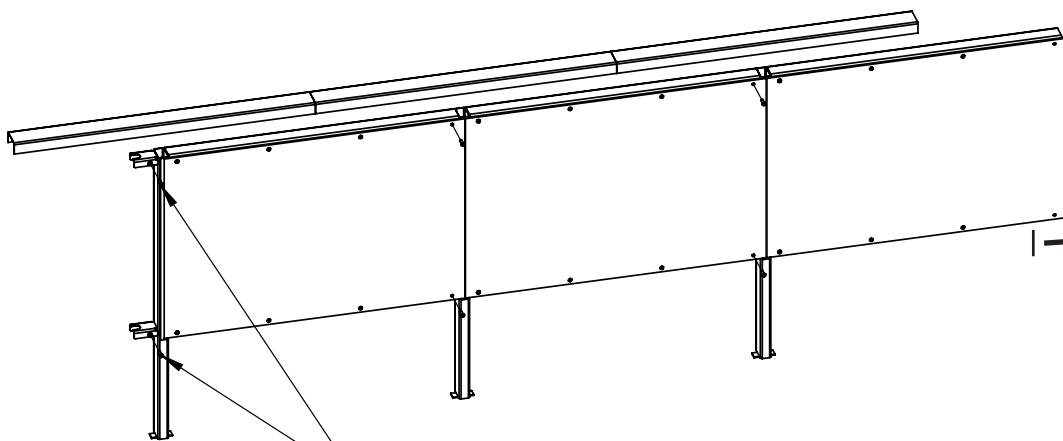

For next connection

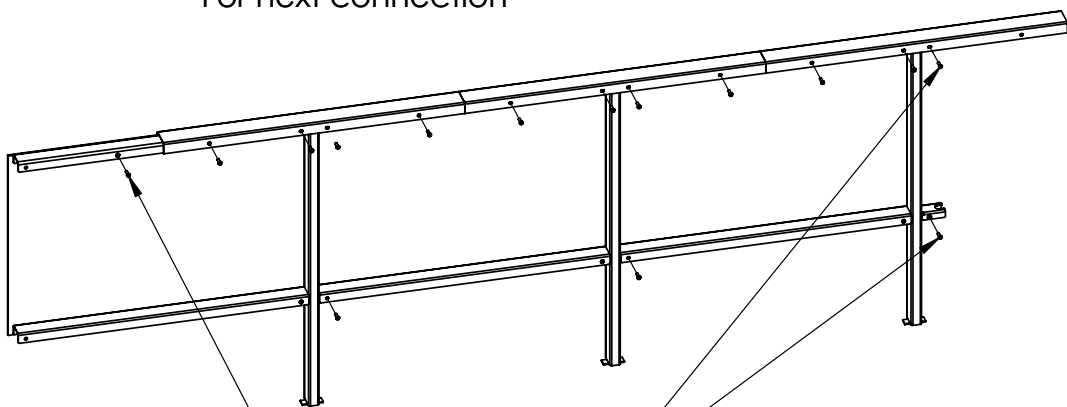

For next connection

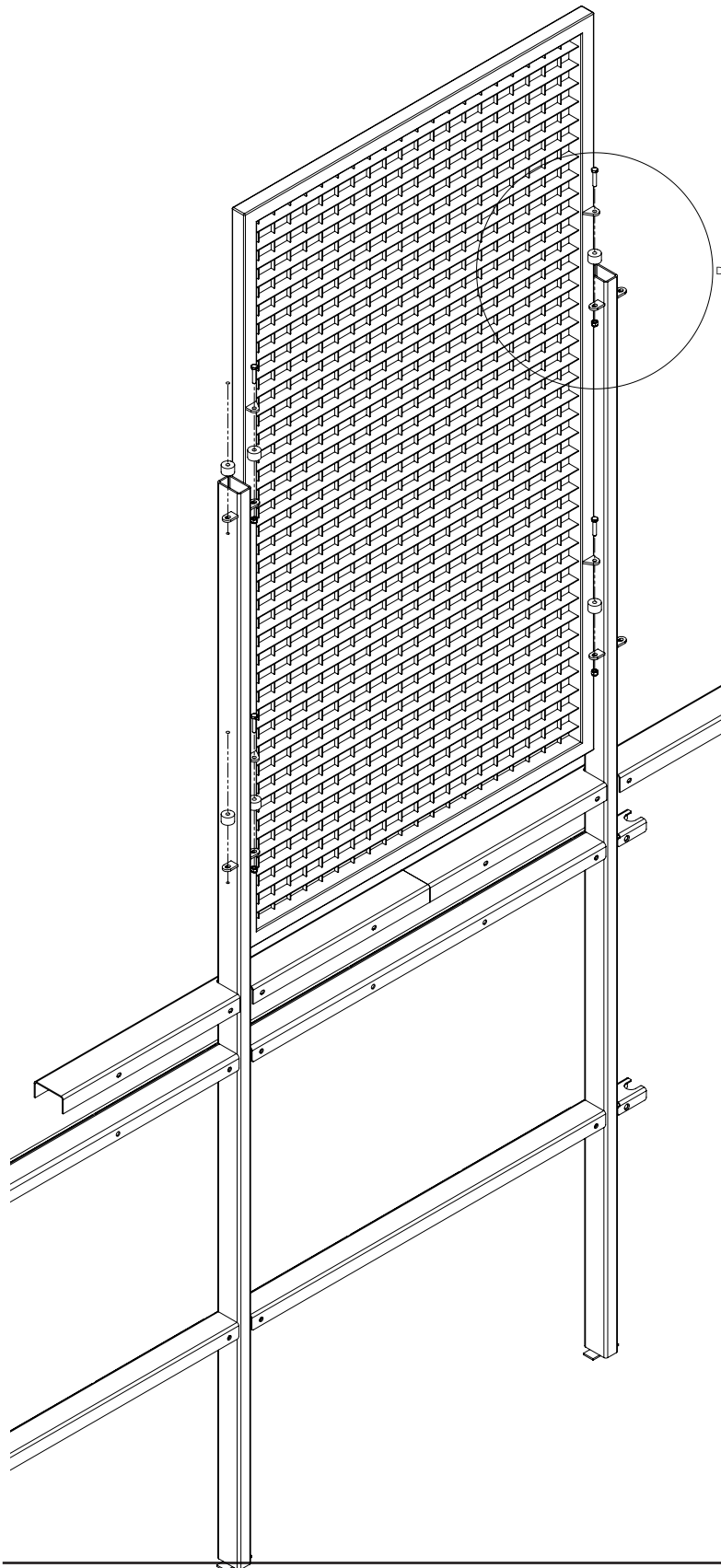

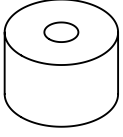
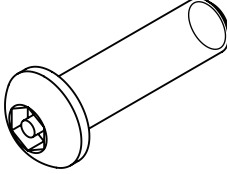
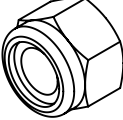
079-170	1 PCS	100-205	4 PCS
			
Default		Damper 30 x 20 x M8	
100-213	4 PCS	100-271	4 PCS
			
Bolt M8 x 40 mm secured		Torque nut M8	

